



410 Sprints

1.1 CHASSIS-Any sprint chassis is allowed, but it must pass any test prescribed by the safety inspectors. The roll cage must be of a four-post design. Sprint cars only. Wheel base no less than 83" and no more than 90". No elliptical tubing used on or part of the main frame structure.

Slip-tubing is not allowed in the chassis construction. This includes safety bars. Any existing slip-tubing must be replaced or welded.

The following measurements are minimum, suggested material: ASTM4130 normalized.

TOP RAILS: 1 ½" x .095

BOTTOM RAILS: 1 3/8" x .095 or 1 ½ " x .083

ROLL CAGE UPRIGHTS: 1 3/8" x .083

ROLL CAGE TOP CROSS MEMBERS: 1 ½" x .095

UPPER RAILS: 1 3/8" x .083

REAR END SAFETY BAR (mandatory): 1" x .083 or 1 ¼" x .065

BRACE: 1 ¼" x .065

1.1A Chassis Support bars

All chassis are required to have additional bars installed to support and decrease the span between the front and rear uprights in the driver's area. The support bars must be in addition to the front and rear uprights. Any attempts to manipulate the front and rear uprights to conform to these measurements will not be allowed. These additional bars will be minimum 1.375 X .083 ASTM4130 normalized steel or equivalent material as per Huset's Speedway current rule 1.0. Left and right-side support bars may be one of the three designs below. Left and right-side support bars do not have to be of the same design.

Left and right-side support bars may be one of the three options:

1. Support bar may be designed similar to what was known as a "safety bar". It must be attached to the top rail at a point 15" -20" from the rear of the upright. It must attach to the hip rail and have a gusset attached to the rear upright near a point opposite of the rear brace/shock mount bar. The curve must be between 4" – 7" measured from outside of the rear upright tube to the outside of the support. (See #1)
2. Existing chassis with a left side support bar installed (formerly called safety bar) that do not meet the option one specification above, may add a gusset that attaches to the top rail 15" – 20" from the rear of the front upright and angle to the support bar. The existing support bar tubing must meet the minimum as described above (1.375 X .083 ASTM4130 normalized steel or equivalent material). (See #2)
3. A support bar may be added to the top rail at a point 15" – 20" from the rear of the front upright and to the rear upright near a point of the rear brace/shock mount bar but no higher than 7" above the hip rail. This bar may have a slight curve near the rear upright to accommodate elbow room and ease of fitment. (See #3)

#1 Support Bar

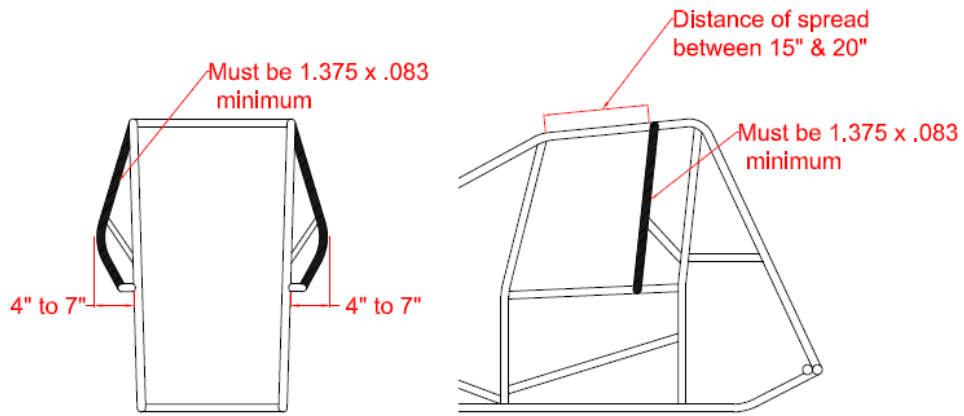

Diagram 16.12.1
By Tom Devitt

#2 Support Bar

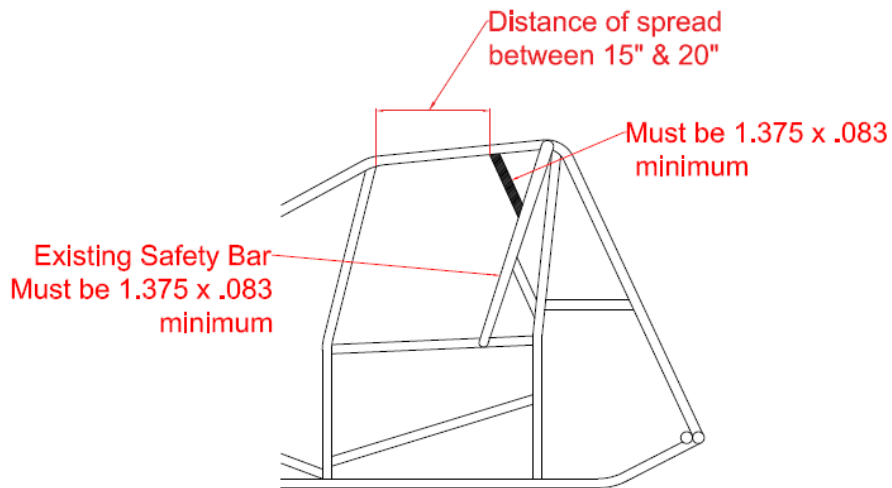
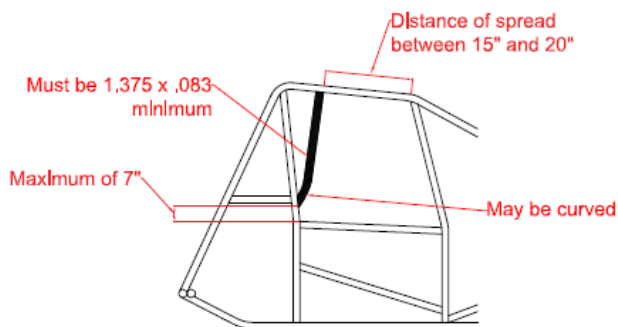
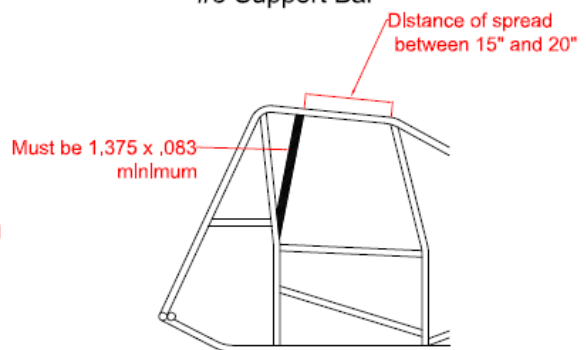

Diagram 16.12.2
by Tom Devitt

#3 Support Bar Curved Option



#3 Support Bar



Drawing 16.12.3
By Tom Devitt

No additional anti roll/weight transfer bars on the racecar.

1.2 WEIGHT RULE – Weight rule for the 410 class in 2022 is 1425 lbs. including the driver, at the conclusion of the race. Cars not making weight will be penalized to last in that event. Any bolt on weight must be painted white and the car number must be on the weight. Loss of any bolt on weight during competition will disqualify the individual from that event. The weight must be securely attached and must remain in place during a race. It must not be moved or removed during a red flag situation. Place in approved only mounting points behind the radiator and in front of fuel tank. We reserve the right to disqualify any individual whose weight mounting procedure does not meet our specifications.

1.3 ENGINE RULES

- A.** Only small block V-8 engines with the cam in the block and a maximum of 410.00 cubic inches of displacement (tolerance + 0.000) will be permitted. The formula $6.2832 \times \text{bore}^2 \times \text{stroke}$ will apply. Big block engines will not be permitted.
- B.** The engine must be mounted in-line with the driver and the drive-line must pass beneath the driver on center through the driver compartment. Offset engines and/or offsetting the position of the engine will not be permitted.
- C.** The engine block and cylinders must be machined from cast aluminum. Billet machined blocks and/or cylinder heads will not be permitted.
- D.** Engines with the magneto and/or distributor in a forward mounted and/or front mounted position must be approved prior to competition.
- E.** Only normally aspirated engines will be permitted. Turbo chargers, super chargers and/or forced induction of any type and/or description will not be permitted.
- F. The maximum engine cylinder bore size shall be 4.165.**
- G.** All engine cylinder sleeves (inserts) must be machined from an iron and/or steel alloy.
- H. Titanium crankshafts, connecting rods and/or rod caps will not be permitted.**
- I.** Only two (2) valves and one (1) spark plug will be permitted per cylinder.
- J.** Cylinder heads must retain a traditional valve pattern. Rotation of the valves will not be permitted. Cantered or splayed valve cylinder heads must be approved prior to introduction into competition.
- K. Only steel connecting rods with a maximum length of 6.000 inches will be permitted.**
- L.** All oil pans must have an inspection plug. The inspection plug must be a #12AN fitting or 1.00" pipe plug. In the event that an engine does not have an inspection plug the oil pan must be removed for inspection prior to competition.
- M.** Only throttle plate (butterfly) and shaft throttle body styles with round circular bores will be permitted. The maximum throttle bore as measured at the throttle plate (butterfly) may not exceed 3.000 inches in diameter. Slide plate, rotary cylinder, and/or other styles must be approved prior to competition. Carbon Fiber manifolds and/or any other injection type pieces manufactured from carbon fiber will not be permitted. (Does not include stacks).
- N.** A maximum of only 16 fuel nozzles, utilizing two (2) per cylinder will be permitted. One (1) nozzle must be placed in the cylinder head and one (1) nozzle must be placed in the injector.
- O.** A minimum of two (2) throttle return springs must be used to mechanically return the throttle to a fully closed position.
- P.** Only magneto-type ignitions will be permitted. A single crank-trigger type system will be permitted as a backup ignition system. One (1) switch that alternates the current between the

magneto and the crank trigger may be mounted to the dashboard within the driver's reach. Multiple coil-pack ignitions will not be permitted.

Q. Steel and stain-less steel headers will be permitted. Titanium headers will not be permitted.

R. In the event that there are new engine components and/or a new engine configuration they must be submitted for approval to Huset's Speedway prior to being introduced into competition.

1.4 FUEL TANKS

A. The same fuel cell/tank must be used in the same car for the entire race program. The fuel cell/tank may be changed at the discretion of Huset's Speedway Officials. Fuel tanks must be securely fastened. Any means of mounting the tank must meet the approval of the officials. A fuel cell with bladder and foam will be the only type fuel cells permitted. The fuel cell must be of one piece construction of cross-link polyethylene plastic. **Alterations and modifications will not be permitted.**

B. Fuel additives, including but not limited to nitro, nitro methane and/or nitrous oxide injection will not be permitted. Pure methanol and/or other approved fuels will be permitted. Fuel samples may be taken from time-to-time for inspection and analysis.

1.5 TIRE RULE 410 CLASS

Right rear Hoosier 105/16" Medium compound tire is required. Left rear is H12 or H15. Front Tire is Hoosier 85/8" D12, D15, D20

Tire Soaking/Doping/illegal tires:

Tire Soaking/Doping is strictly prohibited! Randomly during post feature car inspection, one predetermined finishing order car in the top 3 will have 2 samples taken with a tire groover of the right and/or left rear tire. Both samples will individually be placed into evidence bags, sealed, dated and signed by both car driver and Huset's Speedway official. One sample will be sent to a certified contractor for testing, the second will be kept on file with Huset's Speedway. If the sample comes back good, Huset's Speedway will incur the testing charges. If the sample comes back chemically altered and found illegal, the following penalties will be enforced;

Penalty Phase:

- 1st offense is a 30-day suspension from all Huset's Speedway events, a \$2000.00 fine, and loss of all accumulated season points to date.
- 2nd offense is a 1-year suspension from date of infraction, a \$2000.00 fine, and loss of all-season points.
- Refusal of taking tire sample for inspection constitutes admission of guilt and all penalties listed will be enforced.

Tire rules may be changed according to the rules of the sanctioning body for that event, providing Huset's Speedway/NOSA officials approve the changes.

Illegal Tire Penalty:

Any car/driver lined up in staging for heats/feature or at the finish of either race is found with another compound of RR or LR other than the listed ones above will be automatically disqualified from the entire event. No points or pay for the event. A 2nd infraction will be suspension for the remainder of the year for all Huset's Speedway events.

1.6 Drag Links and Tie Rods:

Drag Links must be made of 4130 steel, a minimum of (1) inch diameter. Only magnetic steel Tie Rods are permitted. (No Aluminum Tie Rods or Drag Links) Drag Links must be tethered to the frame with a minimum of (1) inch nylon webbing. Only magnetic steel Rod Ends/Heim Joints are permitted for Tie Rods and Drag Links.

1.7 BUMPERS & NERF BARS* All rear bumpers must be steel, no titanium, minimum one inch in diameter, minimum .065 thick. The front bumper must not extend past the more than eight (8) inches from the frame and/or the measurement from the center of the front axle to the front of bumper must not exceed 23 ½ inches. Left and right nerf bars must attach to the chassis in three (3) points. Minimum 1.00 " diameter and .065" material thickness.

1.71 -FRONT AXLES* Magnetic steel only.

410: Minimum front axle size:

2 1/2" diameter x 0.095" wall and thicker

2 3/8" diameter x 0.095" wall and thicker

*2 1/4" diameter x 0.120" wall and thicker

*2" diameter x 0.156" wall and thicker

1.8 Radius Rods & Torsion Arms:

Radius Rods can be made of steel or aluminum. Aluminum Rod Ends/Heim Joints are allowed for Radius Rods Only! Rear Torsion Arms can be made with aluminum or Chromoly Steel and must be equipped with Chromoly/Steel Heim Joints (No Aluminum)!

1.9 Drive Line:

All cars must have a driveline strap and/or a driveline hoop restraint constructed of magnetic steel either welded and/or bolted to the chassis. The rear cross member must be used for mounting the hoop.

1.10 Fuel Cell:

Fuel Bladders are mandatory. No carbon fiber or composite material shells allowed.

1.11 Brakes:

There must be at least two working brakes.

1.12 Traction Control Devices:

1. Traction control devices of any type are not permitted at any time, during any event.
2. Any team found with a traction control device in pre and/or post-race inspection shall be disqualified from that event. Additional penalties, including indefinite suspension and/or fines, and/or any penalty deemed appropriate by Huset's Speedway Officials. From time-to-time random inspections will occur and various components may be impounded for further analysis and inspection including, but not limited to ignition systems, ignition boxes, wiring looms and/or tachometers.

1.13 Wings:

Top Wing:

1. Center Foil maximum size of 25 square feet with a maximum width of 60 inches with a one degree plus or minus tolerance.
2. Center Foil shall be fully sheathed in aluminum. Vent holes are strictly prohibited.
3. No wicker bills or Gurney lips permitted on Dished Top Wings. Flat Top Wings will be allowed up to a 2" inch wicker bill.
4. Other than the slider mechanism, no moving parts allowed on or in foil structure.
5. The 12-inch section located at the rear of the Center Foil must not have the belly/curl arc out of proportion with the rest of the Center Foil. The belly/curl arc must span the entire length of the Center Foil and appear to be a gradual arc with the deepest point no further back than 48 inches from the leading edge. As measured on a 12-inch straight edge, the belly at 6 inches from the rear of the Foil may not be deeper than 1/2 inch. There is zero tolerance on this 1/2inch depth. It is suggested that the wing blue-print specify 15/32-inch depth, so that if any deflection or movement of the wing occurs, the depth will not exceed the 1/2 inch specification. (This 1/2inch measurement ensures that the belly/curl arc is gradual.) The belly/curl arc must start at the radius of the Center Foil's leading edge and shall not exceed a depth of 2 1/2 inches. Center Foil thickness cannot exceed 9 inches. Center Foil top surface from side to side must remain flat. Center Foil must be one-piece construction.
6. No split or bi-wings will be permitted.
7. Wings must be fabricated of metal alloys only. No fiberglass, carbon fiber or other similar material may be used in the basic framework of the wings.
8. Top wing must not extend beyond outside of rear tires.
9. Two stationary foils or rudders will be allowed to run the entire length of the underneath portion of the top wing. Maximum height proportions are 1 inch at the front and 3 inches at the rear. Nowhere shall the foil exceed 3 inches in height.
10. The top wing can be cockpit/driver adjustable in the forward and backward directions only.
11. Wing Posts- Wing T-Post will be built from 1" X.083" minimum ASTM 4130 normalized steel or equivalent material.

Wing attachment designs will be subject to approval. The only cast pieces approved will be HRP Part #HRP8811-A75-HD. If new T-Post designs are developed they must be submitted for approval.

Side Board Panels:

1. All side board panels must be within an eight-degree plus or minus tolerance and be square to center foil.
Side panels may not be supported by braces whose section is not horizontal. All braces or supports shall be oriented thin edge to face the air stream. Only rectangular, round or oval metal braces not exceeding 1 inch in width may be used.
2. **No aero section side panel brace material allowed.**
3. No brace or support shall resemble a wicker bill or a split wing.
4. Top Wing sideboards maximum size, 72 inches long and 30 inches tall. Panels must be of one- piece construction. Panels must be fabricated flat so as to have no turnouts or flaps made of more than 2 inches of material on the front or rear of panel and no more than 1 1/4 inches on the top or bottom.
5. Front Wing side boards maximum size, 12 inches tall and 26 inches long with no more than one- inch overhang from the center foil front edge to the side board front edge. Sideboards may have front, back, top and bottom turnouts of no more than 1/2 inch.

Front Wing:

1. Center Foil maximum size of 6 square feet with a maximum width of 36 inches with a one degree plus or minus tolerance.
2. Center Foil shall be fully sheathed in aluminum. No vent holes allowed.
3. Wicker bills up to 2"-inch are allowed on nose wing, flat or dished.
4. Maximum distance from the Center Foil front edge to the front edge of the front axle may not exceed 20 inches.
5. The Center Foil front edge must remain at least 1 inch behind the front edge of the front bumper. Center Foil top surface from side to side must remain flat.
6. Center Foil must be one piece. No split or bi-wings will be allowed.
7. Wings must be fabricated of metal alloys only. No fiberglass, carbon fiber or other similar material may be used in the basic framework of the wings.
8. The Front Wing must not extend beyond outside of front tires. The Front Wing may not be cockpit or driver adjustable while the car is stationary or in motion.
9. No moving parts allowed on or in foil structure.
10. The 5" section located at the rear of the front foil must not have a bell/curl arc that is out of proportion with the rest of the front foil. As measured on a 5-inch straight edge, the belly at 2 1/2 inches from the rear of the foil may not be deeper than 3/8 inch. There is zero tolerance on this 3/8-inch depth. It is suggested that the wing blue print specify 11/32-inch depth, so that if any deflection or movement of the wing occurs, the depth will not exceed the 3/8-inch specification (This 3/8 inch measurement ensures that the belly/curl arc is gradual).
11. The belly/curl arc must span the entire length of the front foil and appear to be a gradual

arc with the deepest point, no further back than 12 inches from the leading edge. The belly/curl arc must start at the front foil's leading edge and shall not exceed a depth of 2 inches. Top foil thickness cannot exceed 3.6 inches.

12. No rudders or fins on Front Wings.

1.14 Points Races

A. Drivers are allowed to miss ONE race to be eligible for year end point fund money, not including rain outs.

B. If the races are canceled after the teams have unloaded, show up points will be awarded if hot laps are completed.

C. ALL Season shows on the schedule will awarded track points including the Border Battle at Jackson Motorplex June 17 & 18. World of Outlaws events will only award show up points.

